

Quick Start Guide

Flow Demo Board FS5/FS7, OOL

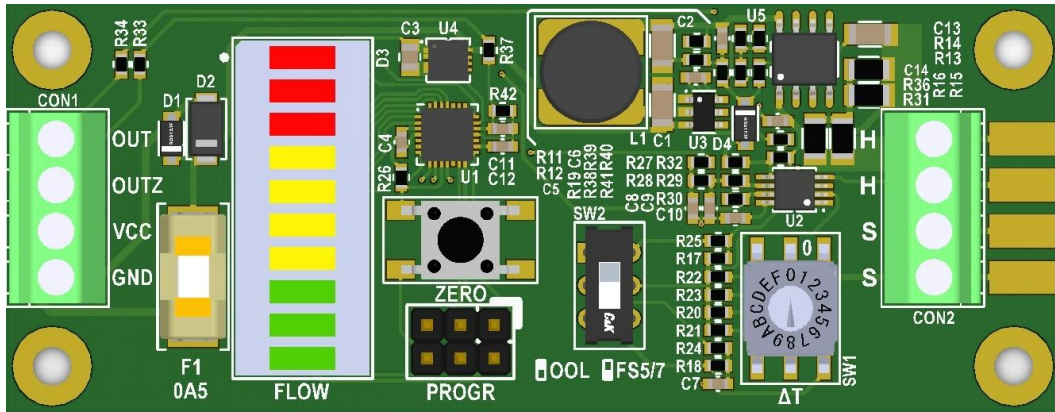

Front side of Flow Demo Board



Back side of Flow Demo Board

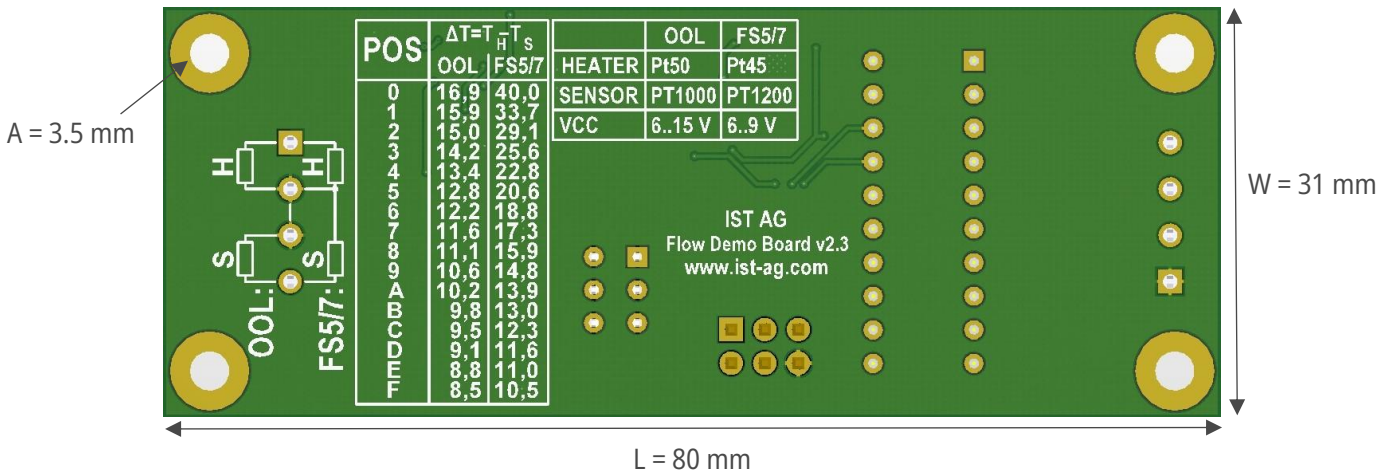

How to connect PCB:

- For OOL sensor move switch to "OOL" position, for FS5 or FS7 sensor to "FS5/7" position.
- Connect the sensor to CON2 terminals according to the diagram on back of PCB: Heater to terminals "H", temperature sensor to terminals "S" (screw or solder them directly to pads). For FS5 or FS7 sensor please connect sensor's common wire to one of the middle terminals of CON2.
- Select desired difference of temperatures between heater and temperature sensor using ΔT switch and the table on back of the PCB.
- Connect power supply to CON1: positive to "VCC", negative to "GND". For OOL sensor no more than +15 V, for FS5/7 no more than +9 V.
- Connect voltmeter to CON1: positive to "OUT" or "OUTZ", negative to "GND".
- Switch on power supply.
- For zero flow press "ZERO" button in order to subtract zero flow offset from LED bar and "OUTZ" output, note that "OUT" output will remain unaffected.
- The OOL sensor is directional, flow's direction should be: from temperature sensor to heater.



Wiring for OOL Sensor:

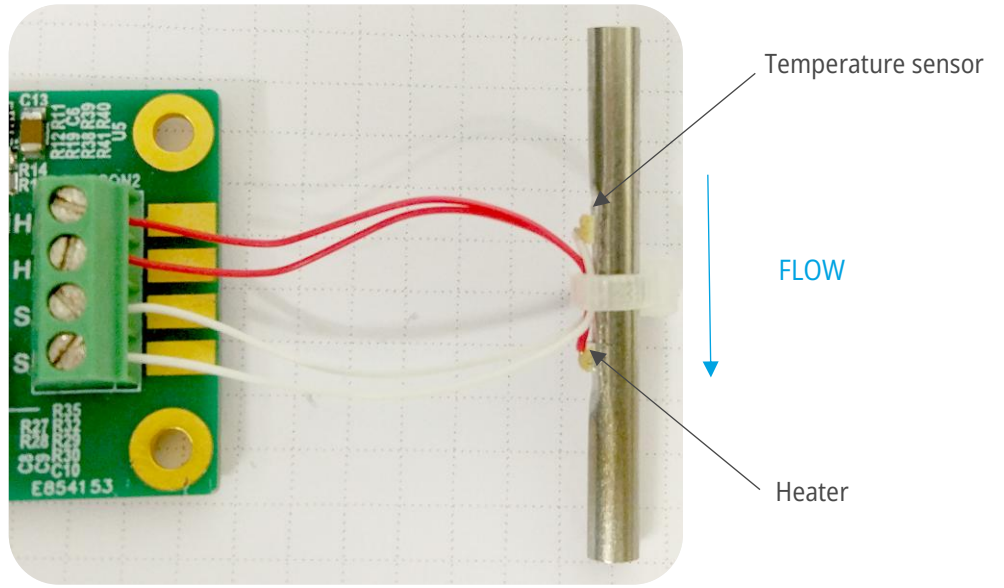

Wiring for FS5/FS7 Sensor:

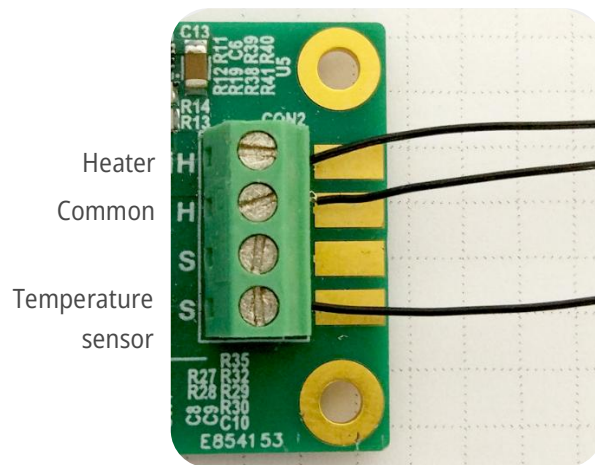
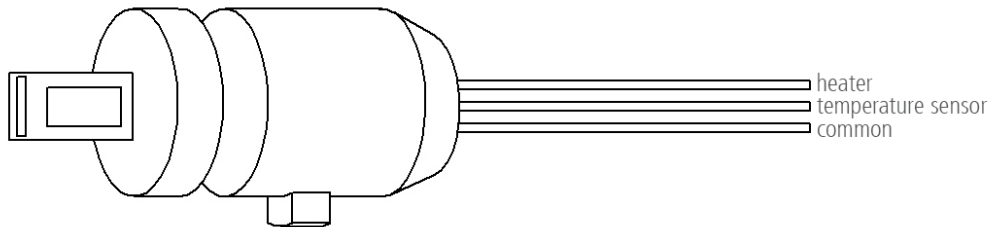
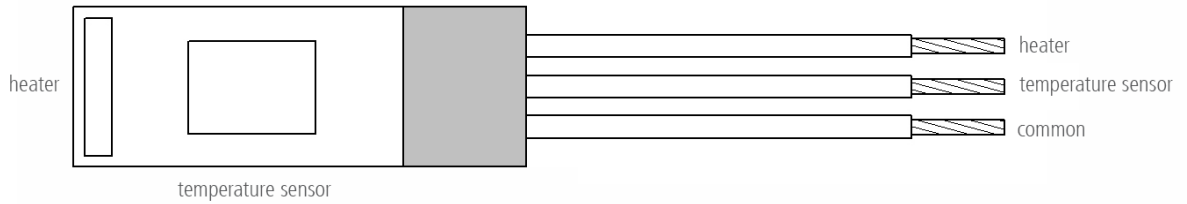



How the PCB works:

- The PCB measures flow using the Constant Temperature Anemometer (CTA) principle.
- During normal operation CTA will always keep the temperature of the heater (T_H) above the temperature of the sensor (T_S) by a constant, predefined value $\Delta T = T_H - T_S$.
- The CTA is made using an analog Wheatstone Bridge with simplified diagram:

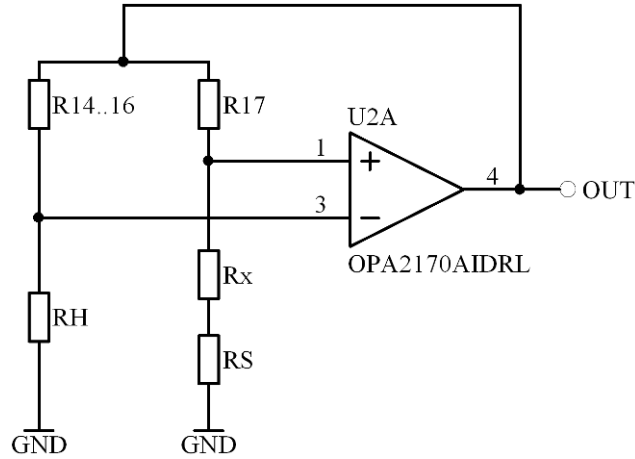

- PCB's output voltage "OUT" is connected to the bridge.
- Additionally, the PCB has the "OUTZ" output allowing the user to measure flow without zero flow offset (zero flow = zero volts).
- Maximum power dissipated in the sensor / maximum "OUT" voltage can be limited using supply voltage: $U_{OUT(max)} = VCC - 2V$. Maximum VCC current should not exceed 0.4 A.
- The PCB is protected using 0.5 A fuse F1, if PCB does not respond please check the fuse.
- The total value of R14..16 sensors is 21 Ω , for OOL sensor R17 = 420 Ω while for FS5/7 sensor R17 = 560 Ω .
- Please note that Flow Demo Board is not temperature-compensated.

Typical characteristics

FS7 Sensor

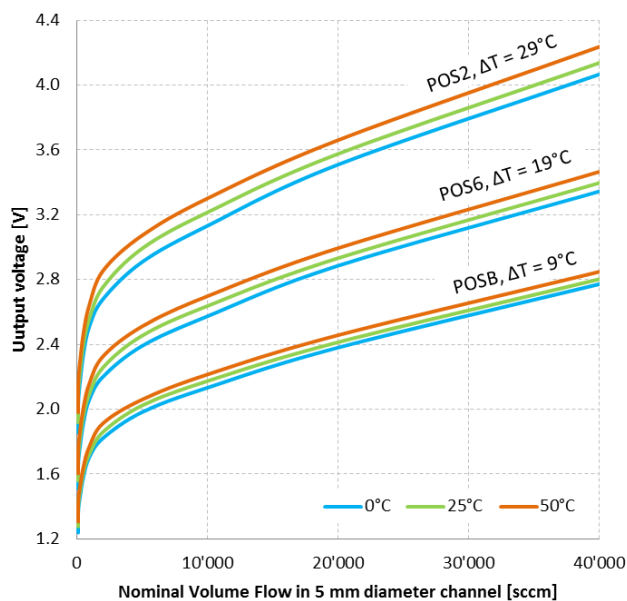

OOL Sensor

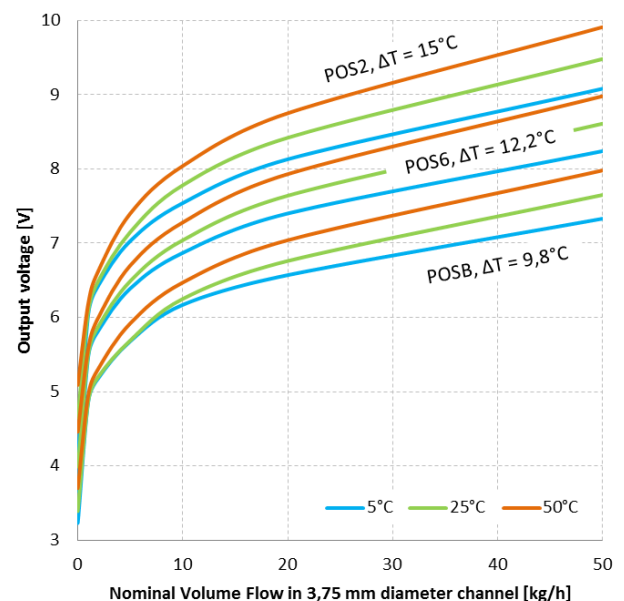



Order information



Product name	Order Code
--------------	------------

Board without sensor	108327
----------------------	--------



Board with FS7 sensor (with housing)	104018
--------------------------------------	--------



Board with 6 mm Out of Liquid sensor	104019
--------------------------------------	--------

Board with 4 mm Out of Liquid sensor	104021
--------------------------------------	--------



Board with Real Probe sensors	104022
-------------------------------	--------



Additional Documents:



	Document name:
--	----------------

Data Sheet:	DFFS5_E DFFS7_E DFOOL_E DF_Demo_Board_E
-------------	--

Application Note:	AFFS5_E AFFS7_E
-------------------	--------------------



Innovative Sensor Technology IST AG • Stegrütistrasse 14 • 9642 Ebnat-Kappel • Switzerland
+41 71 992 01 00 • info@ist-ag.com • www.ist-ag.com

Technical specifications are subject to change without prior notice. The information contained in this data sheet has been carefully reviewed and is believed to be accurate; however, no liability is assumed for any errors or omissions. Continuous exposure to extreme operating conditions may impact product lifetime or reliability. The customer is solely responsible for assessing the suitability and fitness of the product for their specific application. This product is not designed, authorized, or warranted for use in life support or safety-critical applications. The customer agrees to hold the supplier harmless from any claims, damages, or liabilities arising from such use. No explicit or implied warranties, including but not limited to warranties of merchantability or fitness for a particular purpose, are provided. The material provided herein may not be reproduced, adapted, merged, translated, stored, or utilized in any form without prior written consent from the copyright holder. No transfer of any intellectual property rights is granted or implied. All rights reserved.