

## FS.DS.A

### Thermal mass flow sensor

Optimal for low gas flow applications up to 150 °C

#### Benefits & characteristics

- Easy adaptation in various applications and housings
- Simple signal processing
- Simple calibration
- Stable platinum technology
- Excellent reproducibility
- Excellent long-term stability
- Symmetrical heater design and heightened sensitivity
- Customer-specific sensor available on request

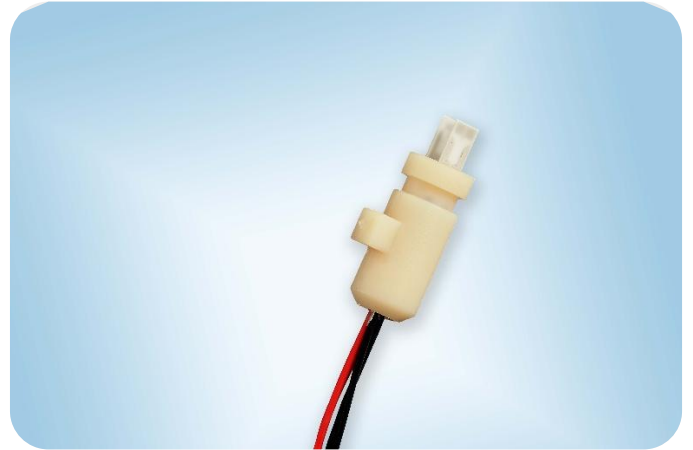

#### Illustration<sup>1)</sup>

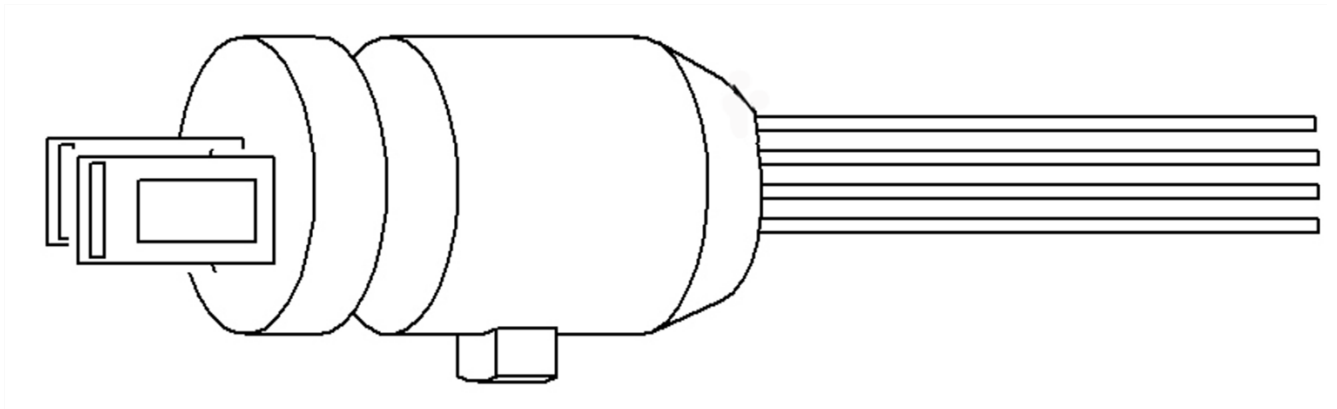

1) Schematic drawing, for actual size see technical data



## Technical data



Dimensions (L x W x H / H2 in mm):\*

Housing:  $\varnothing$  6.0 ( $\pm 0.1$ ) mm,

$L_H = 14$  ( $\pm 0.2$ ) mm

Sensor elements (outside hotmelt):

4.0 ( $\pm 0.2$ ) x 2.4 ( $\pm 0.2$ ) mm (LxW)

Distance between sensor elements:

2.4 ( $\pm 0.2$ ) mm

Operating measuring range:

0 m/s to 100 m/s

Response sensitivity:

0.01 m/s

Accuracy:

< 3 % of the measured value (dependent on the electronics and calibration)

Response time  $t_{63}$ :

~200 ms (jump from 0 to 10000 sccm)

Operating temperature range:\*

-20 °C to +150 °C

Temperature sensitivity:

< 0.1 %/K (dependent on the electronics)

Connection:\*

4 pins, AWG 30/7, stranded wire, insulated with PTFE,  
Colour coding:  
red = heater, black = temperature  
155 mm long, 5 mm stripped

Heater:\*

$R_H$  (0 °C) = 45  $\Omega$   $\pm 1$  %

Reference element:\*

$R_S$  (0 °C) = 1200  $\Omega$   $\pm 1$  %

Voltage range (nominal):\*

2 V to 5 V (at  $\Delta T = 30$  K ( $0 \text{ m/s} \leq v_{\text{gas}} \leq 100 \text{ m/s}$ ))

Maximum heater voltage:\*

3 V (at 0 m/s)

Sealing ring:

compatible with o-ring  $\varnothing$  4 x 1.5 mm

\*Customer-specific alternatives available



## Order information



Product name	Description	Order code
FS.DS.A.1L.155	Double flow Sensor	155846



## Additional Electronics



Product name	Description	Order code
Flow Demo Board	Evaluation Electronics	104018



## Additional Documents



### Document name:

Application Note	AFFS7_E
------------------	---------



Innovative Sensor Technology IST AG • Stegrütistrasse 14 • 9642 Ebnat-Kappel • Switzerland  
 +41 71 992 01 00 • [info@ist-ag.com](mailto:info@ist-ag.com) • [www.ist-ag.com](http://www.ist-ag.com)

Technical specifications are subject to change without prior notice. The information contained in this data sheet has been carefully reviewed and is believed to be accurate; however, no liability is assumed for any errors or omissions. Continuous exposure to extreme operating conditions may impact product lifetime or reliability. The customer is solely responsible for assessing the suitability and fitness of the product for their specific application. This product is not designed, authorized, or warranted for use in life support or safety-critical applications. The customer agrees to hold the supplier harmless from any claims, damages, or liabilities arising from such use. No explicit or implied warranties, including but not limited to warranties of merchantability or fitness for a particular purpose, are provided. The material provided herein may not be reproduced, adapted, merged, translated, stored, or utilized in any form without prior written consent from the copyright holder. No transfer of any intellectual property rights is granted or implied. All rights reserved.