

Order information

ESCC Qualified Hi-Rel temperature sensor with qualified extended wires

Nomenclature according to ESA Detail Specification 4006/015

Nomenclature according to IST AG Reference

Hi-Rel temperature thin-film sensors

Your benefits compared to a wire-wound sensor:

- Resistant against thermal cycles
- Vibration-resistant
- Small dimensions (W x L x H: 2.0 x 2.2 x 1.1 mm ± 0.2 mm)
- Light weight
- No movable parts
- 10 mm platinum wires
- EM versions available

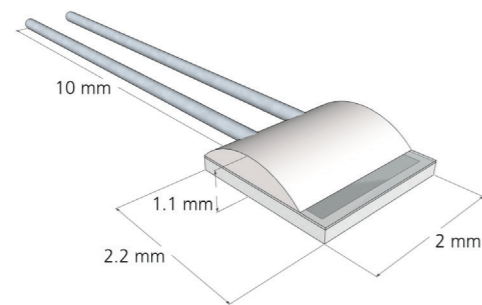

The platinum wires are designed so they can later be processed, e.g. brazing, resistance-welding, laser-welding, crimping and TIN-soldering (elaborately).

ESCC QPL Qualified Part list (sensor only)

Variant Number	Based on Type (Former order code)	Main Reference (Order code)	Nominal Rz (Ω) at 0°C	Operating Temperature Range Top (°C)	Maximum Operating Current	Maximum Rated Current
01	P0K1.232.7W (010.02991)	101410	100	- 50 to +150	1	4
02	P0K1.232.7W (010.02992)	101411	100	-200 to +200	1	4
03	P0K2.232.7W (010.02993)	150026	200	- 50 to +150	0.7	2.8
04	P0K2.232.7W (010.02994)	101412	200	-200 to +200	0.7	2.8
05	P0K5.232.7W (010.02995)	101413	500	- 50 to +150	0.45	1.3
06	P0K5.232.7W (010.02996)	101414	500	-200 to +200	0.45	1.3
07	P1K0.232.7W (010.02997)	101415	1000	- 50 to +150	0.3	1.3
08	P1K0.232.7W (010.02998)	101416	1000	-200 to +200	0.3	1.3
09	P2K0.232.7W (010.02999)	101417	2000	- 50 to +150	0.2	0.9
10	P2K0.232.7W (010.03000)	101418	2000	-200 to +200	0.2	0.9

4006015 XX XX XXXX
 E.g. 4006015 07 01 0300 (same sensor without wires = 40060150700)

Characteristic Code

0100 to 9999 Extension cable/wires nominal total length [mm]

left blank Sensor with platinum leads only

Characteristic Code: Termination Type

00	Sensor with platinum leads only	
01	Twisted 2-core extension cable (no shield)	ESCC Component 390101910B
02	Twisted 4-core extension cable (no shield)	ESCC Component 390101926B
03	Twisted 2-core extension cable with shield and jacket	ESCC Component 390101957B
04	Twisted 4-core extension cable with shield and jacket	ESCC Component 390101973B
05	2-wire extension (single extension wires)	ESCC Component 390101902B

ESCC Component Type Variant Number, Sensor Element

01	P0K1	Temperature range from -50 °C to +150 °C
02	P0K1	Temperature range from -200 °C to +200 °C
03	P0K2	Temperature range from -50 °C to +150 °C
04	P0K2	Temperature range from -200 °C to +200 °C
05	P0K5	Temperature range from -50 °C to +150 °C
06	P0K5	Temperature range from -200 °C to +200 °C
07	P1K0	Temperature range from -50 °C to +150 °C
08	P1K0	Temperature range from -200 °C to +200 °C
09	P2K0	Temperature range from -50 °C to +150 °C
10	P2K0	Temperature range from -200 °C to +200 °C

Detail Specification Reference: 4006/015

QP. XXX. 232. X LXX. B. XXX
 E.g. QP. 1K0. 232. 1 L10. B. 300

Total length

from 100 mm up to 10'000 mm

Tolerance class

B IEC 60751 F.03

Wire / cable type

10	ESCC 3901 019 10B
26	ESCC 3901 019 26B
57	ESCC 3901 019 57B
73	ESCC 3901 019 73B
02	ESCC 3901 019 02B

Temperature range of sensor element

1	-50 °C to +150 °C
2	-200 °C to +200 °C

Chip-Size

232 2.3 x 2.0 mm (LxW) (only qualified chip size)

Resistance in Ohm at 0 °C

OK1	100 Ohm
OK2	200 Ohm
OK5	500 Ohm
1K0	1000 Ohm
2K0	2000 Ohm

Material identification

Q	Qualified Sensor Element
P	Platinum 3850 ppm/K (P1K0 stands for EM only)